

# Assessment of Soil Characteristics for a region

Vishal Kumar<sup>1</sup>, Yash Goel<sup>2</sup>, Amaan Mehdi<sup>3</sup>

and Prof. Shailja Tripathi<sup>4</sup>

*1Student, Civil Engineering Department, MIET, Meerut, UP, India*

*2Student, Civil Engineering Department, MIET, Meerut, UP, India*

*3Student, Civil Engineering Department, MIET, Meerut, UP, India*

*4Assistant Professor, Civil Engineering Department,  
MIET, Meerut, UP, India*

Meerut Institute of Engineering and Technology, Meerut, Uttar Pradesh, India

**Abstract:-** For the construction purposes of Highrise buildings in Urban Areas or the development of the city and specially for the hilly areas, it is necessary to study all the structural characteristics of soil to make a Durable and Stable structure, as the settlement of soil causes the Failure of the structure. Hence, the testing of soil In situ, OR In laboratory is must, it provides us the study to identify the behaviour of the soil and the soil type. The Geotechnical Properties of soil helps up to define its Shear Strength, Compaction Factor, Water Content, Plastic Limit, Specific Gravity of Soil.

It is necessary to check whether the soil is Silting, Claying, Gravel, Peat, Rock or loam in nature without performing any type of soil tests. Soil testing must include assessment of the behaviour of soils in different temperature, moisture condition, loading and stress conditions. So that, the design can act adversely with all the varing possible conditions.

**Keywords:-** Geotechnical Properties, Shear Strength, Compaction Factor, Water Content, Plastic Limit, Specific Gravity.

## 1. Introduction

The various infrastructures and all the examples of good Civil Engineering and Architecture Buildings like Tunnels, Roads, Bridges, Dams, Historical Monuments, Public OR Private properties, Commercial Buildings and the residential areas need to pre-calculate some mandatory mentions, in the name of Strength, Stablity and Durablity of the Structure. These pre-calculated considerations include various tests, the most important tests is “The study of all characteristics and behaviour of the Soil”. In this, we check and tests all the parameters of the soil of the site which will suitable for all the situation affecting our Structure. These Characteristics of soil include; Bearing Capacity of Soil, Searing Strength, Compaction Factor, Swelling Index, Water OR Moisture Content, Plastic Limit of the Soil and the Specific Gravity of Soil.

In the Construction of the Civil Engineering Structures the various assumptions were made upon the study of the various characteristics of soil. Which are given below:-

- The Soil must have an optimum moisture content.
- The soil must not be Compressible in nature.
- The soil particles are likely to be cohesive in nature.
- The layers of the soil must have enough friction to make a stability in the structure.
- The Swelling Index of soil must be as minimum as possible.

- The soil must have high bearing capacity to easily counteract all the structural forces acting upon it.
- The soil must have high shear strength, to prevent itself from shifting.

The moisture content in the soil can affect our structure and make it unstable as when in the rainy season the soil can absorb enough moisture and make a sudden change in its volume. Whereas, in the sunny season it can lose that moisture content due to evaporation, which can further cause the unstable structure. Hence, the soil must have a low moisture content.

If the soil is Compressible in nature then with respect to time the soil will sink inside the ground which can damage our structure. Hence, our soil must not include compressive nature.

The soil having high Bearing Capacity and Shear Strength can easily counteract all the axial and shear forces acting upon it. When there is a dynamic structure in which the forces are not constant, then the Shearing capacity plays a very important role in preventing the structure from failing.

## 2. Methodology

“Soil testing is the first step in construction deeds, to ensure whether the piece of land meets all the suitability factors for any structure to avoid the dreadful phenomena like **The Leaning Tower of Pisa**”.

### Moisture Content Test

The Water Content Test OR Moisture Content Test of the soil is used to calculate the ability of the soil to absorb the amount of the net water or moisture. It can be calculated by various methods like; Oven Dry Method, Sand Bath Method, Radiation Method, Alcohol Method and Calcium Carbide method.

This test can be performed in situ, or in the laboratory. The measurement of the moisture content is probably the most important test in the geotechnical engineering. It has the advantage equally to the Disturbed and Undisturbed Samples. The Standard method for acquiring the Moisture Content Test is mainly the oven drying method.

In Oven drying method, the moisture content is defined as the mass of water which can be removed from the soil, usually by heating at 105 to 110 Degree Centigrade and is expressed as percentage of the dry mass of the soil. This method takes a lot of time to testing.

The faster moisture content test is, “The Calcium Carbide Method” which can be performed by putting soil sample and the Calcium Carbide in a chamber, the water present in the soil sample reacts with the Calcium Carbide and produce a gas. The amount of gas is equal to the amount of water present. A soil sample is weighted on a portable balance and following a test, the percentage moisture content is read directly from the instrument called Pressure Gauge.



Fig 1. Instruments for Calcium Carbide Method ( Pressure Gauge )

### Particle Size Distribution Test

In this method, we arrange the various sieves in the order given below and the proportion of gravel and larger particles is given by first grinding the soil to disaggregate it and then passing it through a 2mm sieve. The remaining matter is weighted and it's proportion is calculated as the whole soil sample. The arrangement of the sieve in Particle Size and the type of soil is defined by the given table;

Sediment-Texture Classification	Soil Composition	Particle size Diameter (mm)
Clay	Clay	< 0.004
	Very Fine Silt	0.004 - 0.008
	Fine Silt	0.008 - 0.016
	Medium Silt	0.016 - 0.032
	Coarse Silt	0.032 - 0.064
Sand	Very Fine Sand	0.064 - 0.125
	Fine Sand	0.125 - 0.25
	Medium Sand	0.25 - 0.5
	Coarse Sand	0.5 - 1.0
	Very Coarse Sand	1.0 - 2.0
Gravel	Granule	2.0 - 4.0
	Pebble	4.0 - 64
	Cobble	64 - 255
	Boulder	255 - 1000

Fig 2. Arrangement of sieve and the Soil Composition

### Specific Gravity Test

In the Specific Gravity test, the sample of soil is to be kept in a 50ml density bottle. Firstly, we weight the empty bottle (W1), then the sample of oven dried soil about 10 to 20gms cooled in a desiccator, taken into the bottle and then weighted (W2). Then, the amount of distilled water is filled to the top by removing the entrapped air by vacuum then bottle is to be weighted (W3). Now the bottle is to be emptied and clean thoroughly, then it is filled with clean water then again it is weighted (W4). Now, the Specific Gravity is given by;

$$\text{Specific Gravity} = \frac{(W2-W1)}{(W2-W1) - (W2-W4)}$$

### Atterberg's Limit Test

The Liquid Limit., Plastic Limit, Shrinkage Limits are also known as Consistency Limits. The Consistency Limits are important in addition to the Natural Moisture Content.

The liquid limit of soil sample is taken by the help of Cassagrande's Apparatus and the Grooving tool. In this test a groove is made on the surface of disturbed soil sample which contains moisture. The no. of blows counted till the surface of the soil sample close the groove. Usually, the no. of blows are less than 25 blows. This Limit determines the clay soil changes from a plastic state to a liquid state.

This test is used to determine the critical water content of soil. The three main limits; Plastic Limits, Liquid Limits and Shrinkage Limits, shows the levels and attributes of Finely Grained Soil at the various conditions.

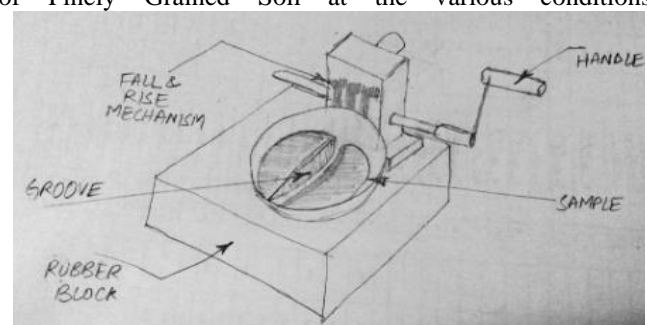

Fig 3. Cassagrande's Apparatus and the Soil Sample Grooved

## Shear Test (Triaxial)

There are two main stages of testing the Shear Strength of the soil are; Consolidation and Shearing. The Consolidation Test can be performed when the stresses are applied on the field naturally due to the Overlaying Strata or structures. But the Triaxial Shear Test is the process of applying the additional stress on the surface of the soil which brings it to the peak failure OR beyond under the specific drainage conditions. The additional load applied on the specimen of soil are correspond to the Field Loading Situation, including both the vertical and horizontal stresses. By the method, we can possibly determine that the type of soil can sustain how much change in the Loading Condition without shifting, and the amount of deformation will occur under normal possible conditions.

The Triaxial Shear Tests are generally performed by considering the possible field conditions as close as possible on a cylindrical specimen. This test can measure all the mechanical properties of soil such as Shear Strength of Soil, Stress-Strain Curves, Volume change and the Pore Pressure Behaviour.

In this test, the unconsolidated and undrained soil sample is prepared having diameter of 38mm and height to diameter ratio is 2. It is to be placed on the pedestal of Triaxial Cell. Then, the cell is assembled with a loading ram and then placed in the loading machine. The cell fluid is admitted to the cell and the value of pressure is raised gradually. The axial compression of the soil sample is recorded with the initial readings of the gauge.

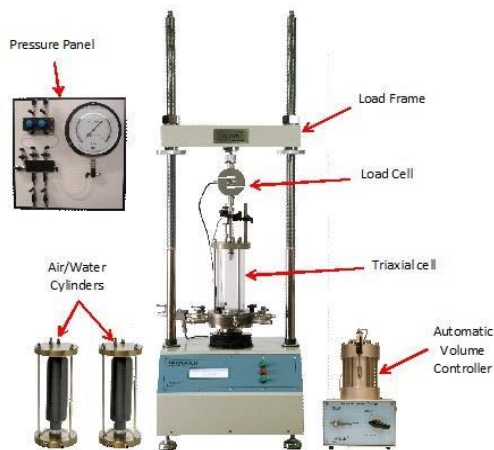

Fig 4. Apparatus for Triaxial Shear Test

## 2.6. Direct Shear Test OR Vane Test

The soil has its Shear Strength due to the cohesive nature of the particles (stress independent) and frictional resistance between the particles (stress dependent). The Shear Failure of the soil takes place because of the stresses between the particles when they slide over each other, which will cause Slippage. This test is carried out to determine the ability of the soil for preventing the Slippage.

In this test, the shear box along with the two specimens (60mm X 60mm) are taken. The specimen with the plane grid plate is placed at the bottom of the shear box. Then, the soil sample is placed in the housing box then the specimen is placed above it for covering. This shear box is placed perpendicular to the direction of loading. The loading pad is kept on the grid plate. Now we gradually apply the load upon the surface of grid plate. The required normal stress applied and the rate of longitudinal displacement with respect to shear stress application so adjusted that no drainage will occur in the sample during the test(1.25mm/min). The upper part of the Shear box is removed in such a way that the gap between the two parts of the shear box will remain 1mm. This process is repeated twice or thrice for two or more soil samples.



Fig 5. Direct Shear Test OR Vane Test Machine

## 2.7. Consolidation Test

Consolidation of soil means the rate of change in volume of the soil gradually by the response to change in external pressures. The compressible soils may have consolidation in a longer term, due to the loads imposed by the foundations above ground structures. The settlement can also be occur if the applied pressure is within the safe bearing capacity of the soil.

The consolidation test is one of the soil tests which may very helpful to testing the undisturbed soil samples. In this test, the undisturbed soil sample is to be placed in a consolidation ring of 60mm diameter. Then, the thickness and the weight of the sample is recorded. The specimen is to be sandwich between the two Porous stone. A filter paper is placed between the Porous stone and the specimen. Then, the loading cap is mounted on the top, the consolidometer is placed with the loading device and the loading can be suitably adjusted. Then, the dial gauge clamped in order record the movement between the base of the consolidation cell and the loading cap. A seating pressure of 0.05 kg/cm<sup>2</sup> is applied to the specimen.

The consolidation cell is kept filled with water and the test will continue after 24 hours using a loading sequence of 0.25, 0.5, 1, 2, 4, 8 kg/cm<sup>2</sup>. Then, the readings of dial gauge are recorded after the incremental loading up to 24 hours. From the observations the Void Ratio-Log Curve will be obtained.

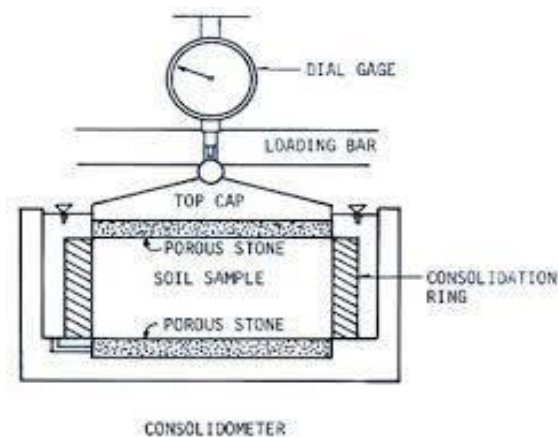

Fig 6. Arrangement of Soil sample in a Consolidometer

The other consolidation test is one dimensional consolidation test, which is also referred as incremental loading oedometer test. In this test, the radially constrained samples are loaded in a sequence starting stress close to the over burden pressure of the soil samples. Then, the load is increased two or three times than before. The loading repeated 4 or 5 times, with a final unloading sequence. The Vertical displacement of the soil is calculated through the dial gauges with the accuracy specified in BS 1377, ASTM D2435 and D4546. The management of the Consolidation Test be possible by the automatic data acquisition system and a PC software.



Fig 7. A three-gang consolidation test device along with automatic data acquisition device

### Differential Free Swell Index Test

An oven dried soil sample is taken, in order to calculate the swelling characteristics of the soil. We use the differential free swell test for calculate the swell index of the

soil. To perform this test, we take our oven dried soil sample and pass it through 425 micron sieve and then it is poured in two 100 ml graduated cylinder. One is to be filled with distilled water till the top and other one is to be filled with the kerosene to the top, by removing all the entrapped air. Then, to check the change in volume of the soil, we give sufficient time to the soil sample to achieve the equilibrium state of volume. After this, we record the final volume attain by the soil in each cylinder.

$$\text{DFS} = \frac{\text{Soil Volume In Water} - \text{Soil Volume In Kerosene}}{\text{Soil Volume In Kerosene}}$$

### Digital Automatic Testing

A dedicated software is developed for the soil testing to BS, ASTM and AASTHO standards in Geotechnical Laboratories, which is named Data System Software. The latest version of (DS 7.3) contains many features like automatic data logging (analysis and reporting). By the help of DS Software we can improve the efficiency of the laboratory and can eliminate the operator error, it allows the staff free for the any other task.

The DS System Software improves the testing quality of soils such as in Triaxial Shear Test, Vane Test, Compaction and Consolidation Test e.t.c. The DS 7.3 enables instructions to step by step procedure, in conjunction with Electronic Data Acquisition Unit OR GDU. It can prevent the potential errors or man-made errors and gives accurate readings. The reports can be generated under chosen standards and can be printed as a hard copy.

## 3. LITERATURE REVIEW

• **Biswas Uprety, (2020)** “Comparison of bearing capacity calculation methods in different site conditions”. The foundation for any civil structure is designed according to bearing capacity of the soil at the site. There are several papers where bearing capacity of the soil are determined. Various methods use various scales of safety factors so result of the bearing capacity is different in every method. This paper works on the previously published work “Investigation of Soil and Bearing Capacity in Different Site Condition, (2012)”. This paper also compares the different factors that affect the bearing capacity of soil like shape of footing, foundation depth and depth of water table.

• **R. Gayathri Devi, P.J. Chandrasekhara Rao, S.S. Asadi, (2019)** “Creation of Land Resources Information System using Geoinformatics: a Case Study”. The limitation of land available for urbanization in a highly populated country like India is a challenge, and to use the agricultural land to meet the urbanization requirements, needs proper planning and data of land use/land cover. By preparing the digital thematic maps i.e., Base map, slope map, drainage map, Transportation map, Hydrogeomorphology map etc., They created a land use land cover classification scheme for the satellite images of 2014 and 2018. With help of these technologies only the change detection analysis had been done in less time and at low cost. In the present

study it is clear that more than 20% of the area is effected by erosion. In future in the study area this may lead to sedimentation and other consequential problems to the near by water bodies.

• **G. S. Sarma, SS. Asadi and S. Lakshmi**

**Narayana, (2016)** "Geospatial Data Based Modelling For Evaluation of Soil Properties: A Modal Study". The soil quality is attracting attention for the last couple of years due to the unscientific and unplanned irrigation practices that are bringing a myriad problem. The present study is an attempt made to analyze the physico-chemical parameters and to generate the Soil Quality Index.

• **Sumedh Yamaji Mhaske, et.al., (2009) Indian Geotechnical Society** on "Application of GIS-GPS for mapping Soil Index Properties" . Index properties of soil such as specific gravity, moisture content, dry density, wet density etc. are the important parameters in geotechnical engineering and they are changing from place to place both along the depth and width of the stratum. It is important for the geotechnical engineers to know about variation of the index properties of soil before carrying out design and construction of any geotechnical structure. Any field or laboratory soil testing will provide result by which is too specific for a particular location to generalize over an extended area. In this paper, an attempt is made to develop a methodology to map the important index properties of soil by using Geographic Information System (GIS) and Global Positioning System (GPS) using existing soil exploration reports.

## 4. CONCLUSION

Geotechnical engineers can run more queries of various combinations regarding the various properties of soil which will help in decision making process. This paper will benefit to Geotechnical Engineers, Consultants, Investigators and Clients in the following manner:

- Updated information can be maintained regarding soil index properties Reduces time for decision making as all information is in one system
- Various maps can be generated in vector Analysis module which will depict the updated soil characteristics.
- Helps to the contractors in knowing about the soil profile beforehand about the start of their work
- GPS can be used for mapping positioning of boreholes during night shift or any weather condition.

Two types of soil from two nearby sites have been studied to evaluate their physical and engineering properties and the following conclusion has been drawn.

- A significant loss in the natural moisture content occurs with elapsed time which renders the laboratory determine moisture content of the soil different from its natural in-situ condition.
- Specific gravity for both the soils are obtained to be similar.
- Wet sieve analysis purports the better PSD

characterization of soils because the fine particles such as silt and clay cannot be easily separated during dry sieve analysis, which renders improper PSDs.

- It was observed that even if the soils from both the sites were of similar gradation, their engineering characteristics were significantly different. Hence, PSD cannot be used as a sole descriptor for the engineering and geotechnical characteristics of soils.
- Based on the estimated Atterberg limits, as per ISSCS, both the soils are classified as CL-CI, i.e. both the soils show low-to-medium compressibility.
- The compaction characteristics state that soil from Sirwani site comparatively has more strength than the Tumin soil, which is manifested by higher MDD and lower OMC obtained from a standard Proctor compaction test. The high peak shear stress obtained from DST of Sirwani site soil reveal the high angle of internal friction and strength at MDD, indicating that the Sirwani soil would more resistance towards instability.
- Sirwani soil shows a lower cumulative infiltration owing to lesser permeability in its natural state.
- Consolidation test reveals that the Sirwani soil is more compressible, however, will take more time to consolidate as revealed by its lower permeability at all levels of stress.
- The permeability calculated from consolidation test is lesser than the infiltration tests because of the state of the soil sample during the test where it is subjected to continually increasing stress.

Based on the observations and conclusions, it can be stated that although the sites are not located far away from each other, and even though some of the engineering and geotechnical characteristics for both the soil are same, still noticeable difference exists between the two soil sites in their geotechnical manifestations. It is to be noted that both the sites are landslide prone, and these differences in their geotechnical characteristics lead to the variability in mechanisms of failure and should be properly estimated to determine proper mitigation procedures and techniques.

## REFERENCES

1. G. S. Sarma et al., International Journal of Applied Environmental Sciences ISSN 0973-6077 Volume 11, Number 1 (2016), pp. 245-258 Geospatial Data Based Modelling For Evaluation of Soil Properties: A Modal Study
2. Olumide Aderemi Afolabi et. A., Jordan Journal of Civil Engineering, Volume 12, No. 4, 2018 Strength Modelling of Soil Geotechnical Properties from Index Properties
3. SS. Asadi et,a., International Journal of Civil Engineering and Technology (IJCIET) Volume 8, Issue 3, March 2017, pp. 816–823 Article ID: IJCIET\_08\_03\_082 Preparation of soil analysis for construction of commercial complex: a model study
4. R. Gayathri Devi, P.J. Chandrasekhara Rao, S.S. Asadi
5. District Census Handbook of Nellore, Directorate of Census Operations, Andhra Pradesh, Census of India, 1991.
6. Abassi, S. A., Water quality indices: state –of-the art, Journal IPHE, 1999, 21, 22-25.
7. Larson, W. E., and Pierce, F. J., Construction and enhancement of soil quality, SSSA, 1991, 35, 176.
8. NyleC. Brady., The nature and properties of soils, 12th edition, EEE, PrenticHall, 2002.
9. All India Soil and Land Use Survey (AISLUS) (1990). Watershed Atlas of India. Department of Agriculture and

Cooperation. IARI Campus, New Delhi.

**10.**All India Soil and Land Use Survey (AISLUS) (1989). Soil Survey Manual. Department of Agriculture and Cooperation. IARI Campus, New Delhi.

**11.**State Soil Survey, Department of Agriculture, Hyderabad 1988, Soils of Andhra Pradesh, Legend. pp:1:30.

**12.**Eswaran, H., Beinroth, F.H., Reich, P.F., and Quandt, L.A. 1999. Soils: their properties, classification, distribution and management. NRCS.

**13.**Fritton, D.D., and G.W. Olson., 1972, Bulk density of fragipan soil in natural and distributed profiles, SSSA, proc 36,686-89.

**14.**Herrick, J.E., (2000); soil quality; an indication for sustainable land management. Applied soil ecology. 15:75-83.

**15.**K. Hemalatha Reddy and K. Sai Kala, Comparison of Vertical Settlement in Storeyed Building in Different Foundations of Various Soils. International Journal of Civil Engineering and Technology, 8(1), 2017, pp. 748–755.

**16.**Jumikis, A.R. (1965). Soil Mechanics, An East-West Edition, D. Van Nostrand Company.

**17.**Kulkarni, M.N. (2003). Global Positioning System and its Application, CEP Training Course, IIT Bombay, pp. 1–15.

**18.**Phadake, V.R. and Jain, R.K. (1998). Geotechnical Engineering, Nirali Prakashan.

**19.**Ramamurthy, T.N. and Sitharam, T.G. (2005). Geotechnical Engineering [Soil Mechanics], S. Chand.

**20.**Venkatachalam, P. (2006). DST-NRDMS Sponsored Training Programme: Geospatial Technologies and Applications: Principle of GIS, GRAM++ GIS Package Development and Applications, CSRE, IIT Bombay, Mumbai.

**21.** Parr, J. F., Papendic, R. I., Hornic, S. B., and R. E., Mayer, Soil quality, Attributes and relationship to alternative and sustainable agriculture, AJAA, 1992, 7, 5.

**22.** G. S. Sarma, SS. Asadi and S. Lakshmi Narayana, Geospatial Data Based Modelling For Evaluation of Soil Properties: A Modal Study, ISSN 0973-6077 Volume 11. [

**23.** Abdullah Anwar, Sabih Ahmad, Yusuf Jamal and M.Z. Khan, Assessment of Liquefaction Potential of Soil Using Multi-Linear Regression Modeling, International Journal of Civil Engineering and Technology, 7(1), 2016, pp. 373-415.

**24.** K. Hemalatha Reddy and K. Sai Kala, Comparison of Vertical Settlement in Storeyed Building in Different Foundations of Various Soils. International Journal of Civil Engineering and Technology, 8(1), 2017, pp. 748–755.

**25.** IS: 2720 (Part-II)-1973 (Reaffirmed 2002), Methods of test for soils, Part-II, Determination of water content, New Delhi, India.

**26.** IS: 2720 (Part-III)-1980 (Reaffirmed 2002), Methods of test for soils, Part-III, Determination of specific gravity, New Delhi, India.

**27.** IS: 2720 (Part-IV)-1985 (Reaffirmed 2006), Methods of test for soils, Part-IV, Grain size distribution, New Delhi, India.

**28.** IS: 2720 (Part-XL)-1977 (Reaffirmed 2002), Determination of free swell index, New Delhi, India.

**29.** IS: 2720 (Part VII)-1980 (Reaffirmed 2002), Determination of water content dry density relation using light compaction, New Delhi, India.

**30.** IS: 2720 (Part-XIII)-1986 (Reaffirmed 2002), Direct shear test, New Delhi, India.

